

INSTALLATION INSTRUCTIONS

EQUIPMENT REQUIRED: STANDARD SCREWDRIVER

WIRING ACCESS LOCATION: SUV 3

DRILL BITS:

HITCH REQUIRES 5/8" PIN AND CLIP IF STABILIZING PIN IS NOT INSTALLED.

WRENCHES: (TIGHTEN ALL FASTENERS WITH TORQUE WRENCH) 10mm, 21mm, 9/16, 11/16, 3/4

VEHICLE

MERCEDES ML500
 MERCEDES ML430
 MERCEDES ML350
 MERCEDES ML320

DO NOT EXCEED LOWER OF TOWING VEHICLE MFR'S RATINGS OR

| HITCH TYPE ▼ | MAX GROSS TRLR WT(LB) | MAX TONGUE WT(LB) |
|----------------------------|-----------------------|-------------------|
| WEIGHT DISTRIBUTING | 5000 | 500 |
| WEIGHT CARRYING BALL MOUNT | 5000 | 500 |

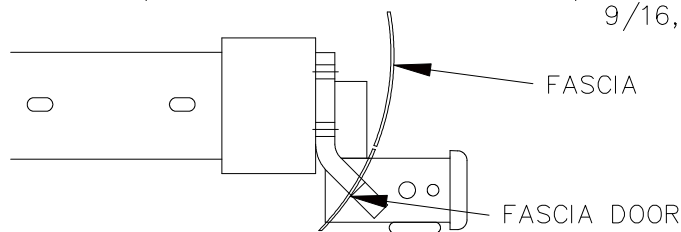

RECEIVER SHOWN IN PROPER POSITION

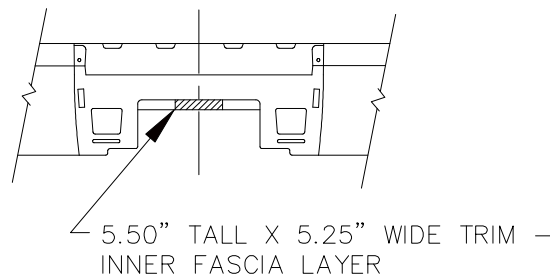
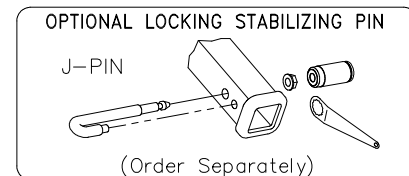
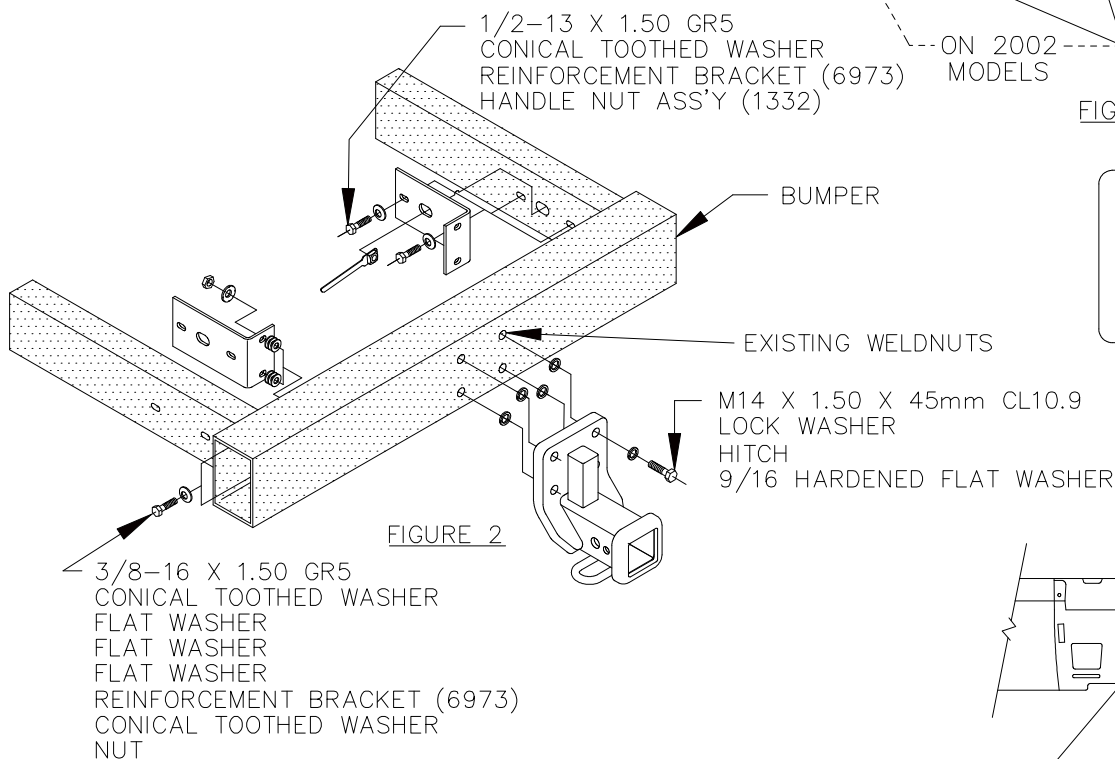
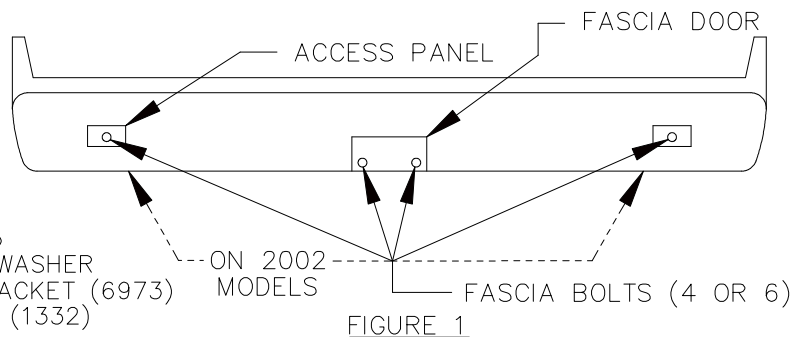

NOTE: USE CAUTION WHEN REMOVING REAR FASCIA. SOME MODELS HAVE A CELLULAR PHONE ANTENNA AND MODULE ATTACHED TO THE FASCIA. FASCIA MUST BE SUPPORTED WHEN REMOVED.

1. REMOVE FOUR (4) OR SIX (6) BOLTS FROM REAR FASCIA AS SHOWN IN FIGURE 1 AND REMOVE FASCIA.
2. REMOVE FASCIA DOOR FROM FASCIA.
3. INSTALL HITCH AND REINFORCEMENT BRACKETS AS SHOWN IN FIGURE 2. (ON 2002 AND LATER MODELS TRIM FASCIA AS SHOWN IN FIGURE 3).
4. REINSTALL REAR FASCIA AND BOLTS REMOVED IN STEP 1.
5. RETURN FASCIA DOOR TO VEHICLE OWNER OR TRIM TO FIT HITCH. CONSULT VEHICLE OWNER BEFORE TRIMMING.

TIGHTEN ALL 3/8 GR5 FASTENERS TO 31 LB.-FT.
 TIGHTEN ALL 1/2 GR5 FASTENERS TO 50 LB.-FT.
 TIGHTEN ALL M14 CL10.9 FASTENERS TO 117 LB.-FT.

THIS PRODUCT COMPLIES WITH SAFETY SPECIFICATIONS AND REQUIREMENTS FOR CONNECTING DEVICES AND TOWING SYSTEMS OF THE STATE OF NEW YORK, V.E.S.C. REGULATION V-5 AND SAE J684.

| | |
|---------------------|--------------|
| APPROX WEIGHT (LB.) | FASTENER KIT |
| 24 | 01131-076 |

NOTE: Check hitch frequently, making sure all fasteners and ball are properly tightened. If hitch is removed, plug all holes in trunk pan or other body panels to prevent entry of water and exhaust fumes. A hitch or ball which has been damaged should be removed and replaced. Observe safety precautions when working beneath a vehicle and wear eye protection. Follow car maker's specs for maximum trailer weight and tongue weight. Do not cut access or attachment holes with a torch.

TOWING PRODUCTS
 Plymouth, Michigan