



# Installation Instructions PowerBoard



Automatic Retracting Running Board







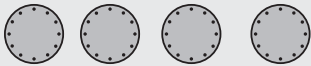

## Vehicle Application

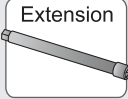
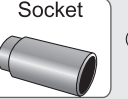
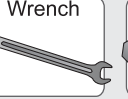
- Jeep Wrangler Unlimited JK  
4 Door Only  
2007 and newer  
Part Number: 75122-15

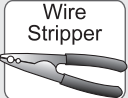

*Note: Rubicon Rock Rails are not compatible with PowerBoards and will need to be removed.*

[www.bestop.com](http://www.bestop.com) - We're here to help! Visit our web site and click on ["Ask a Question"](#). Click here for more [Truck Accessories by Bestop](#).

INSTALLATION TIME	SKILL LEVEL
 <p><b>4 Hours</b></p>	 <p><b>4 - Difficult</b></p>

TOOLS				
 Ratchet	 Extension	 Socket 13 mm	 Wrench 10 mm	 Crimp Tool
 Wire Cutters	 Wire Stripper	 Allen Wrench 4 mm	 Power Drill 1/8" & 3/8" Bits	 Silicone Sealant
 Electrical Tape	 Safety Glasses			



	<b>WARNING</b> The manufacturer strongly recommends that this product be professionally installed.
	<b>WARNING</b> Failure to carefully follow the electrical installation steps could result in severe electrical shock which could harm the installer and/or damage the vehicle.

 **WARNING** Do not rely in any way on the components of this product to protect against injury or death in the event of an accident. Never operate the vehicle in excess of manufacturer's specifications.

**WEAR SEAT BELTS AT ALL TIMES**

Read and follow, precisely, all installation instructions provided when installing product. Failure to do so may result in a poor fit and could place occupants of the vehicle in a potentially dangerous situation.

# PowerBoard – Installation Instructions

## Parts List and Hardware Identification

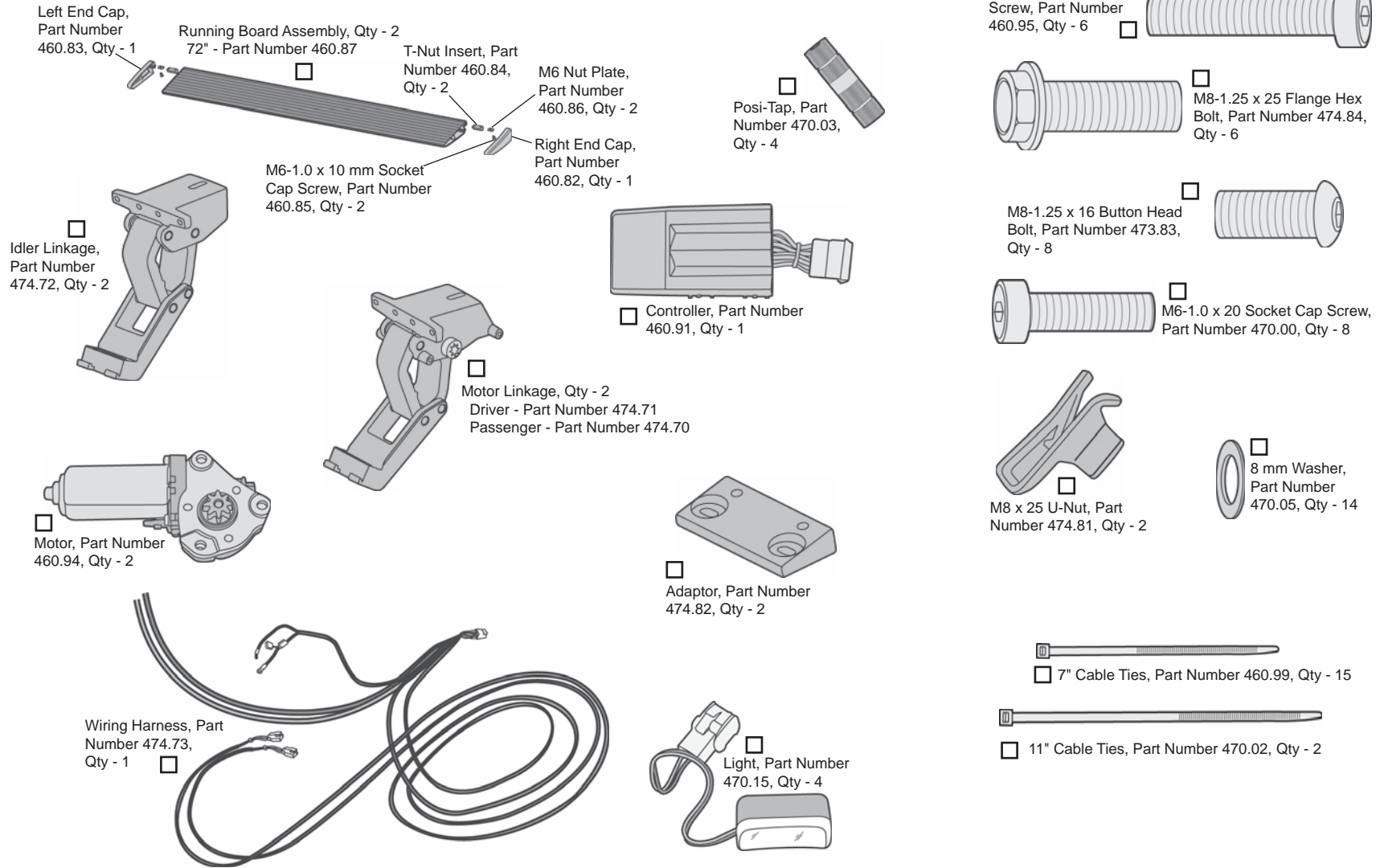

## PowerBoard – Installation Instructions

### 1 Install Adaptor – Passenger Side

Locate the rear linkage position in front of the rear body mount. Install the Adaptor with a Flange Hex Bolt. Tighten the bolts.

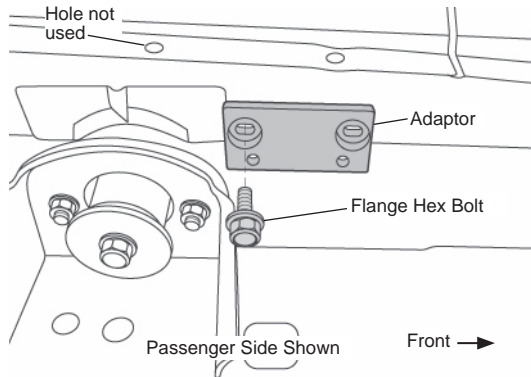

### 2 Install Motor Linkage – Passenger Side

Mount a Motor Linkage with a Button Head Bolt and 8mm Washer at the pinch weld hole and a Flange Hex Bolt in the inboard hole. Mark the pinch weld at the second hole location and remove the linkage. Drill a 1/8" pilot hole at the marked location then drill a 3/8" hole. Reinstall the link using an additional Button Head Bolt and 8mm washer in the drilled hole.

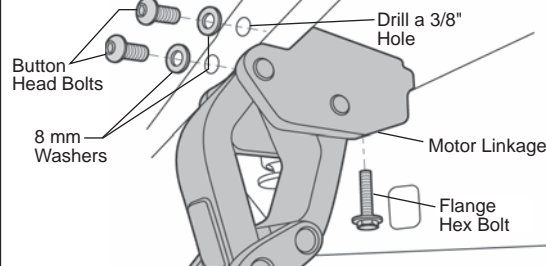

### 3 Install U-Nut – Passenger Side

Install an M8 x 25 U-Nut in the hole next to the Body mount behind the front tire.

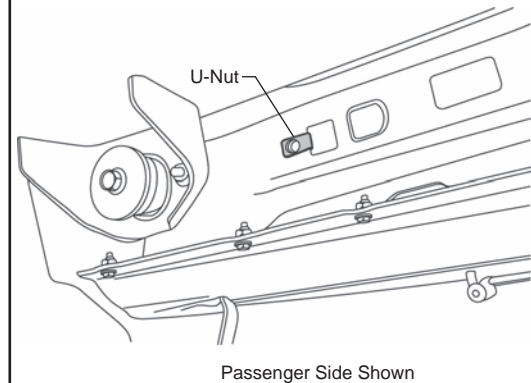

### 4 Install Idler Linkage – Passenger Side

Use two (2) Button Head Bolts and 8 mm Washers and a Flange Hex Bolt to mount the Idler Linkage to the vehicle. Tighten the fasteners. Shim the linkage inboard with 1 to 3 washers between the linkage and the pinch weld on the rear hole so it operates smoothly when the board is attached (2 are usually sufficient).

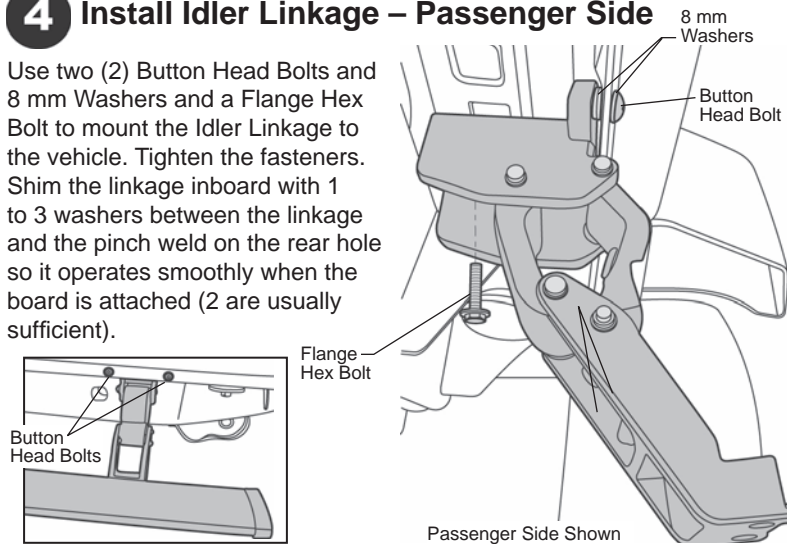

### 5 Install Driver's Side Linkages

Repeat steps 1 – 4 on the driver's side of the vehicle.

**⚠ WARNING** Remove the fuse from the Wiring Harness.

### 6 Remove Fuse from Wiring Harness

Remove the fuse from the Wiring Harness. Failure to do so could result in severe electrical shock which could harm the installer and/or damage the vehicle.

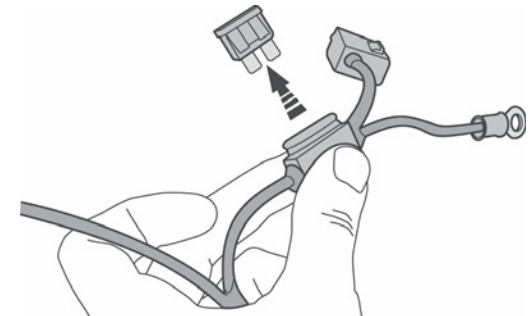

## PowerBoard – Installation Instructions

### 7 Install Controller and Wiring Harness

Secure the Controller to the passenger side firewall with 11" Cable Ties. Connect the red lead to the positive battery terminal and the black lead to the negative terminal.

Connect the Wiring Harness to the Controller.

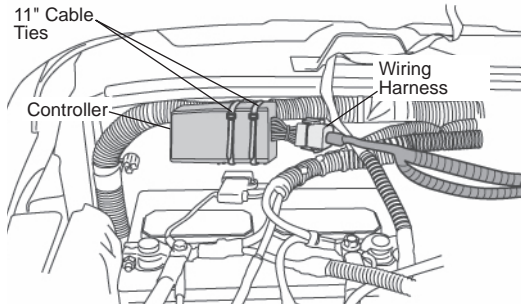

### 8 Route Wiring Harness

Route the long leg of the Wire Harness across the firewall to the driver's side and under the vehicle outside of the frame rail.

Route the short leg down the firewall and outside the frame rail on the passenger side.

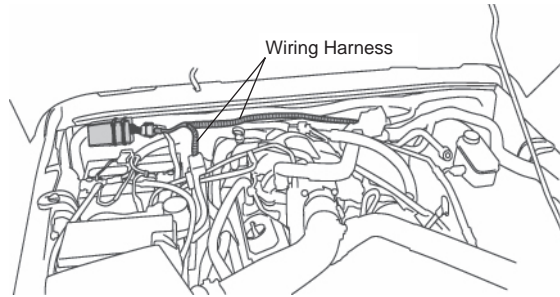

### 9 Remove Front Door Sill – Passenger Side

Remove the front door sill on the passenger side.

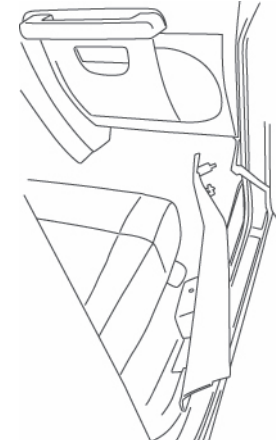

### 10 Route Trigger Wires – Passenger Side

Lift up the carpet. Slit the rubber grommet in the floor. Thread the trigger wires through the grommet into the passenger compartment.

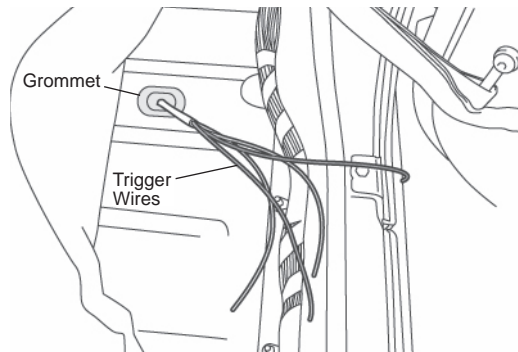

### 11 Connect Trigger Wires – Passenger Side

Use the Posi-Taps to connect the trigger wires to the matching wires in the factory loom.

Violet / White wire in loom coming from front door.

Violet / Yellow and Violet / Grey in main loom in door sill.

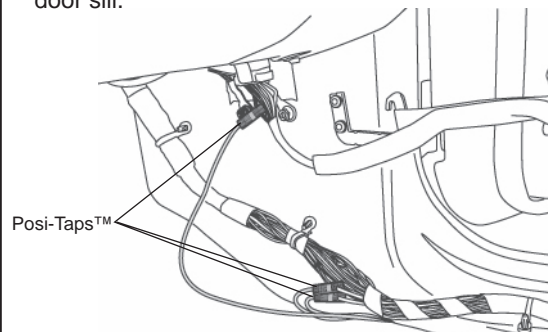

#### NOTE

Occasionally the actual wire color may be different than the one stated here or there may be more than one wire with the same color. You will need to install the motor and test each wire until you find the wire that functions correctly.

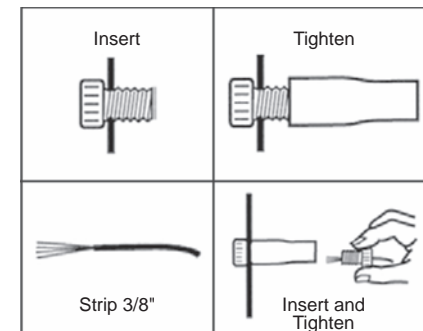

Posi-Tap™ Instructions

## PowerBoard – Installation Instructions

### 12 Remove Front Door Sill – Driver Side

Remove the front door sill on the driver side and pull up the carpet.

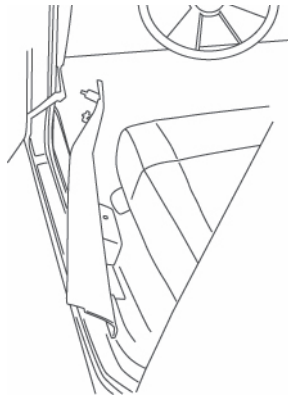

### 13 Route Trigger Wire – Driver Side

Route the Violet wire under the carpet to the door sill. Connect to the Violet wire coming from the door.

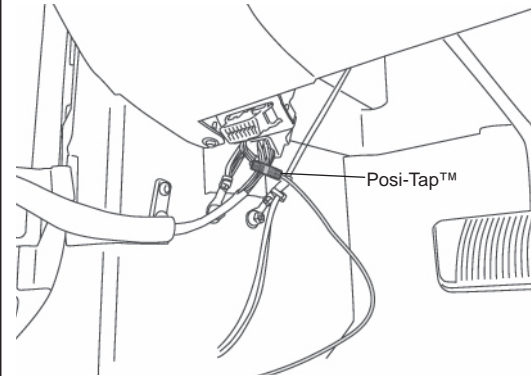

### 14 Install Lights

Clean the outboard surface of the of the flat recess on the Linkage. Peel the adhesive liner off the back of the Light and firmly press it onto the recess. Plug the light into the connector with the black and orange wires in the wire harness. Repeat with the other three lights. Secure loose wires with Cable Ties.

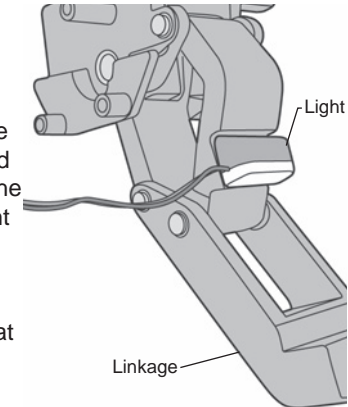

### 15 Install Running Boards

Orient the Running Boards on the vehicle aligning the rear of the board with the rear edge of the back doors. Mount the Steps to the linkages. Slide the mounting T-Nut into position. Install M6-1.0 x 20 mm Socket Head Bolts to secure the boards. Use a 5 mm Allen Wrench to tighten the bolts to 10 ft./lbs. Make sure the board moves up and down freely by hand. If it binds, loosen the linkage to body attachment bolts and adjust the linkage position until the boards move freely. Retighten the linkage to body attachment bolts.

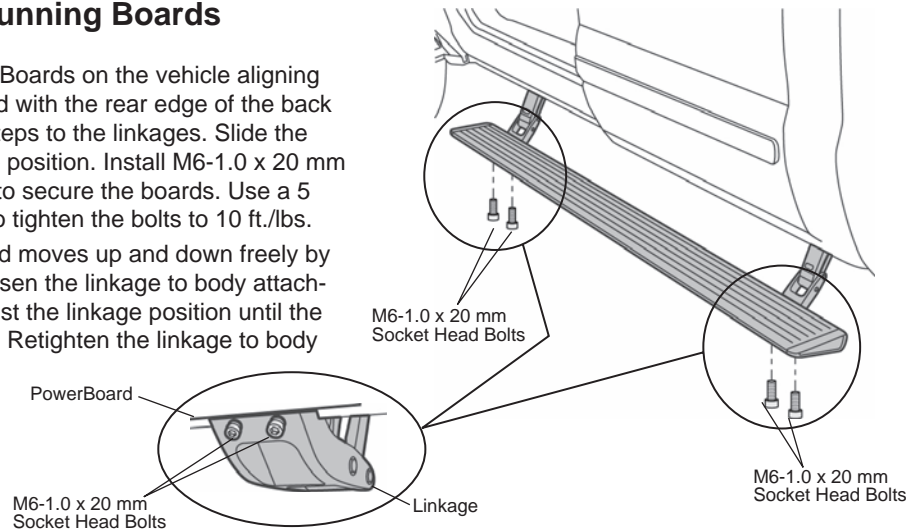

### 16 Install Motor

Slide Motor assembly onto drive shaft and mounting bosses of Motor Linkage assembly. Use three (3) M6-1.0 x 30 mm Socket Cap Screws to secure Motor. Plug female connector into Motor. Wrap any exposed wires from the motor with electrical tape.

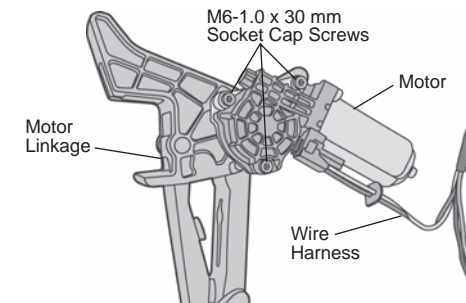



## PowerBoard – Installation Instructions

### 17 Reinstall Fuse

Reinstall the fuse in the harness.

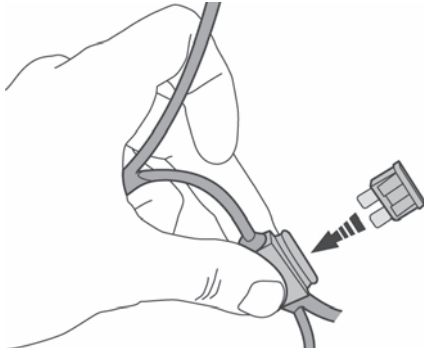

### 18 Test Doors

Open the doors to make sure that the PowerBoard drops into position on each side of the vehicle.

Reinstall door sills.

If the board sags down at the idler link, both front and rear link positions may need to be adjusted. Loosen all the linkage attachment bolts. Push forward at the rear of the board and retighten the bolts while applying pressure.

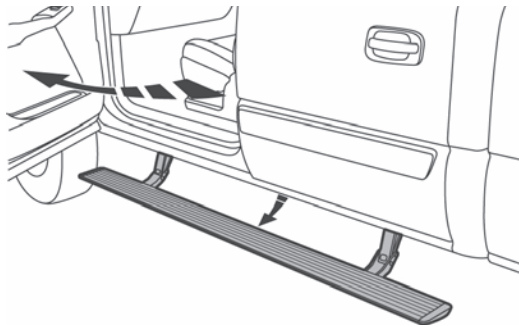

### PowerBoard Troubleshooting

#### Issue:

- Possible cause

#### Boards do not operate:

- Connected to incorrect vehicle wire
- Wire connections not secure
- Fuse burned
- Factory door-ajar circuit inoperable

#### Board creaks or squeaks during operation:

- Gear shaft wedge bolt is loose
- Loosen mounting bracket and board attachment screws. Adjust linkages so they are parallel to each other and the noise is gone. Tighten all fasteners.

#### Intermittent operation:

- Wire connections not secure
- Bad ground
- Bad battery connection

#### Boards operate randomly:

- Wire connections not secure
- Connected to incorrect vehicle wire

#### Board stays down all the time and can be moved by hand:

- Gear shaft wedge screw is missing or loose

#### Board shakes and or shutters during operation:

- Bad ground
- Wire connections not secure
- Bad battery connection

#### One or more doors operate the board and other do not:

- Wire connections not secure

### PowerBoard Service Tips

#### Confirming PowerBoard is functional-black controller:

To test if the black controller (460.91), wire harness, motor and lights work, hook up to battery and touch any of the 4 door trigger wires to ground. The board for that side should go down and the lights should turn on. The board should go up and the lights should turn off when the wire is removed from ground.

#### Boards don't operate correctly when connected to wires identified in instructions:

Unfortunately vehicle manufactures do not consistently keep the same wire colors in their wire harnesses or there may be more than one wire of that color. The PowerBoard trigger wires need to be connected the factory door-ajar wire that is connected to each door latch switch. The correct wire is likely in the same bundle that is identified in the instructions. If none of them work you can locate the correct wire by removing the door panel and tracing the wire bundle that leads to the door latch.

Use an ohm meter or continuity tester to find the door-ajar wire on PowerBoards with black controllers. The correct wire will go from neutral to ground when the door is opened and return to neutral when the door is shut. Connect one test lead to the negative battery terminal and probe the wires with the other lead. You can use a pin or a Posi-Tap connector to pierce the wire insulation. The correct wire will make the tester go from no continuity to complete continuity when the door opened and return to no continuity when the door is shut. You can also shut the door latch with the door open by pushing on the latch catch with a screw driver.

## PowerBoard – Installation Instructions

---

### LIMITED WARRANTY

We warrant our product to be free from defects in material and workmanship, for the terms specified below, provided there has been normal use and proper maintenance. This warranty applies to the original purchaser only. All remedies under this warranty are limited to the repair or replacement of any item or items found by the factory to be defective within the time period specified. If you have a warranty claim, first you must call our factory at the number below for instructions. You must retain proof of purchase and submit a copy with any items returned for warranty work. Upon completion of warranty work, if any, we will return the repaired or replaced item or items to you freight prepaid. Damage to our products caused by accidents, fire, vandalism, negligence, misinstallation, misuse, Acts of God, or by defective parts not manufactured by us, is not covered under this warranty.

THE WARRANTY TIME PERIOD IS AS FOLLOWS FOR ALL PowerBoards MANUFACTURED BY OUR COMPANY: THREE YEARS / 36,000 MILES FROM DATE OF PURCHASE.

ANY IMPLIED WARRANTIES OF MERCHANTABILITY AND/OR FITNESS FOR A PARTICULAR PURPOSE CREATED HEREBY ARE LIMITED IN DURATION TO THE SAME DURATION AND SCOPE AS THE EXPRESS WRITTEN WARRANTY. OUR COMPANY SHALL NOT BE LIABLE FOR ANY INCIDENTAL OR CONSEQUENTIAL DAMAGE.

Some states do not allow limitations on how long an implied warranty lasts, or the exclusion or limitation of incidental or consequential damages, so the above limitations or exclusions may not apply to you. This warranty gives you specific legal rights, and you may also have other rights which vary from state to state.



For further information or request for warranty work, please contact:

Bestop Inc. Customer Service  
Toll-Free: (800)845-3567  
Main: (303)465-1755  
E-mail: [csbestop@Bestop.com](mailto:csbestop@Bestop.com)  
Website: [www.Bestop.com](http://www.Bestop.com)